

Threedimensional analysis of nuclear track detectors with confocal microscopy

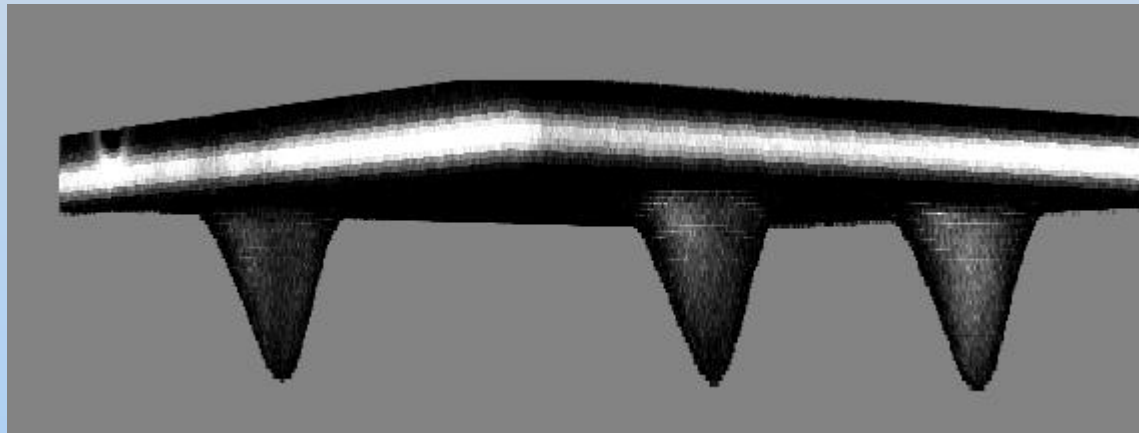

Filip Rooms
(thesis defense may 1999)

Survey

- Introduction and description of the problem
- Radiation in space: a survey
- Track formation and imaging of the detector
 - track formation and particle identification
 - image formation and degradation
 - image restoration
 - image analysis
 - results
- Image analysis: shape fitting
- Conclusions

1. Introduction and description of the problem

- In the past: not much attention for radiation in space
- In the past also usually military missions, short flights, ...
- now more aandacht voor straling
 - International Space Station
 - manned missions to Mars planned

⇒ experiment at Ghent University,
in collaboration with ESA and DWTC to
study the effects of this radiation

2. Radiation in space: a survey

Charged particles → influence of magnetic fields

- Trapped radiation:
 - particles captured in the magnetosphere of the Earth.
 - Mostly protons and electrons
- Radiation from the Sun
 - Solar wind
 - Solar Particle Events
- Cosmic radiation
 - particles with gigantic energies
 - origin is still not clear

3. Track formation and imaging of the detector

1. Track formation and particle identification
2. Image formation (optics and image degradation)
3. Image restoration by deconvolution
4. Image analysis by shape fitting procedures
5. Results

3.1 track formation and particle identification

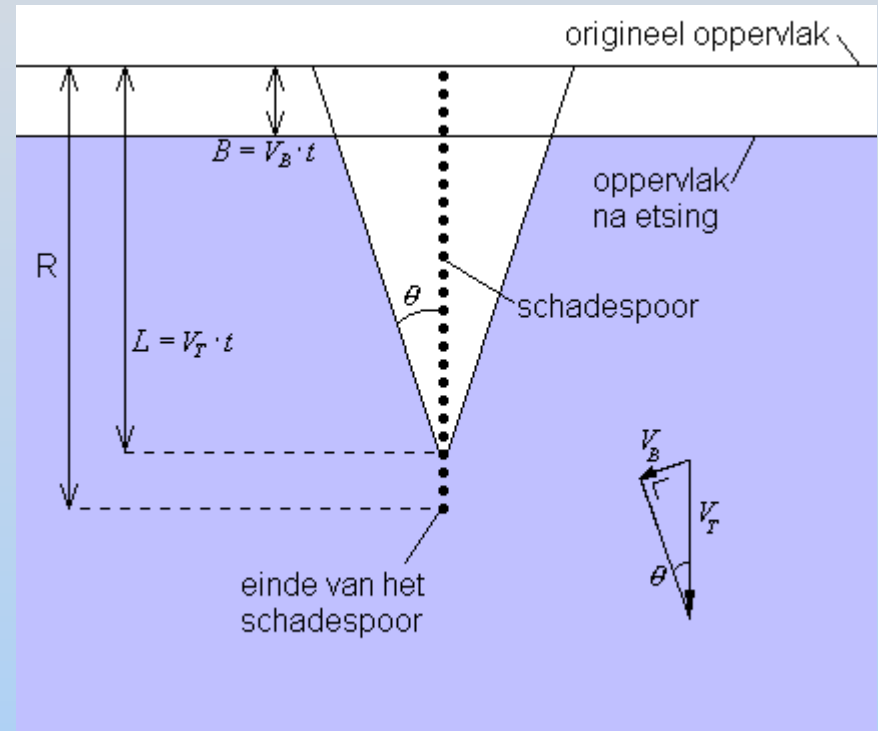
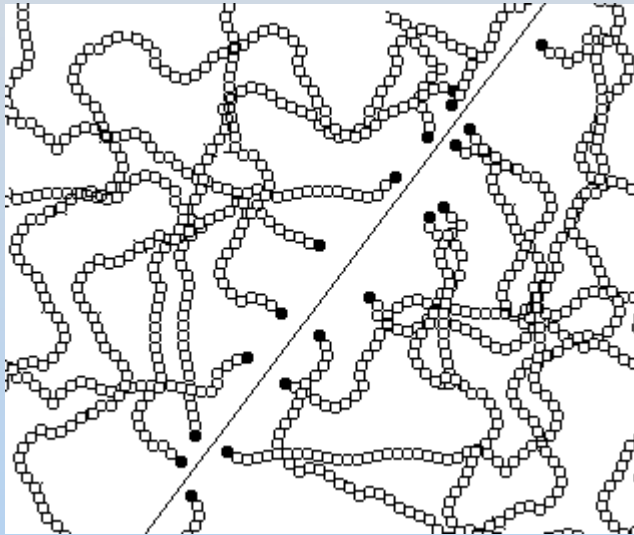

polymere damage and chemical etching

particle identification

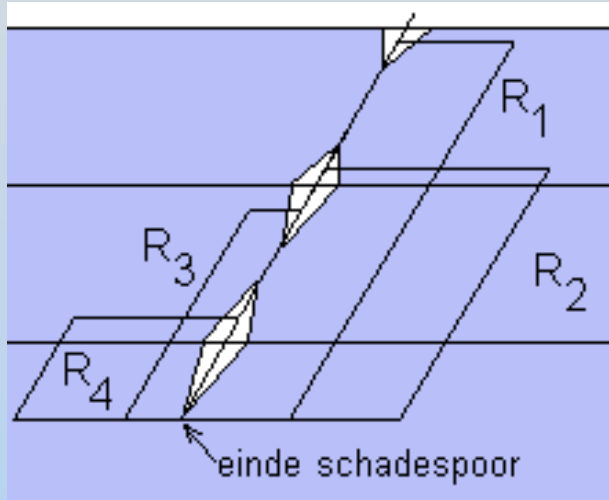

$$\begin{cases} V_T = f(Z, \beta_i) \\ R_i = g(Z, M, \beta_i) \end{cases}$$

Calibration: fitting of $V_T = aJ^n$

Particles with known Z , M , E and $(E-R)$ relations

- measure V_T and R
- fitting of $V_T = xR^y$
- determine β and γ from $J = \beta R^\gamma$
- calculation of a en n

3.2 Image formation (optics and image degradation)

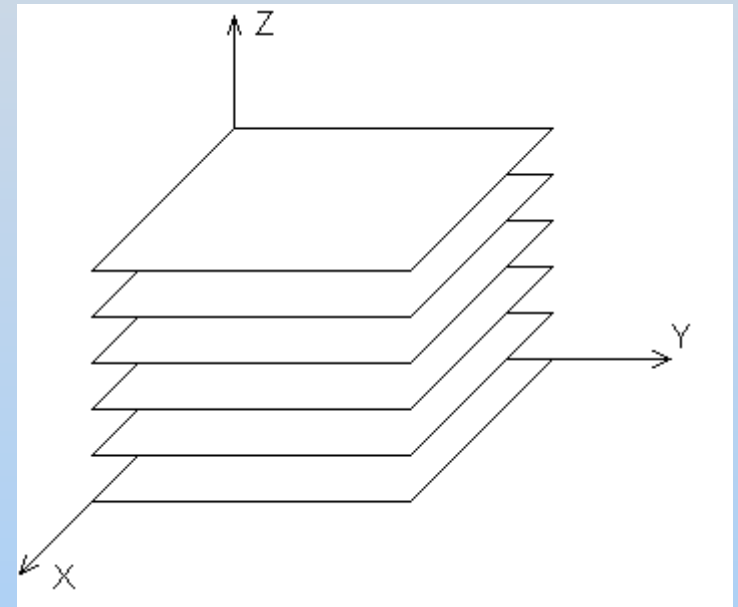
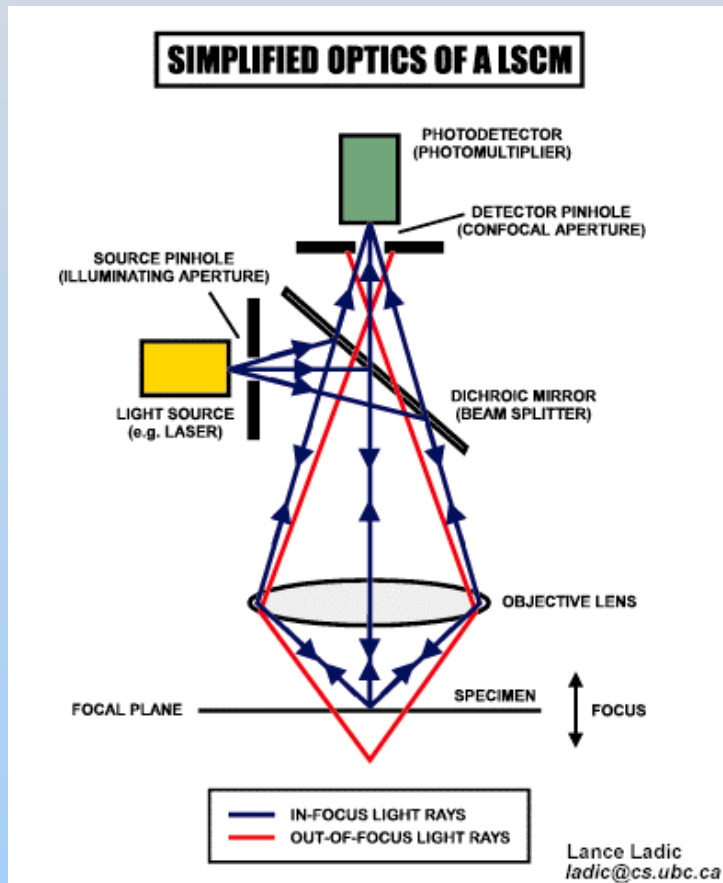

principle of a confocal microscope











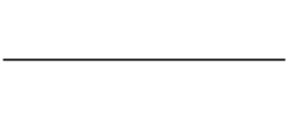
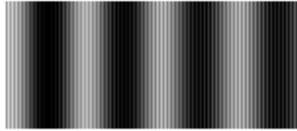
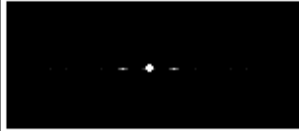

 origineel object			
			enkel nulde orde
			enkel nulde en eerste orde
			nulde, eerste en tweede orde
			nulde tot en met derde orde
beeld	interferentiemaxima doorgelaten	helderheidsprofiel	

Image formation: theory of Abbe

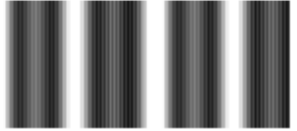
- Image degradation
 - blurring because wave character of light and optics
 - Noise
 - thermal noise
 - sampling noise
 - stochastic ruis
 - ...

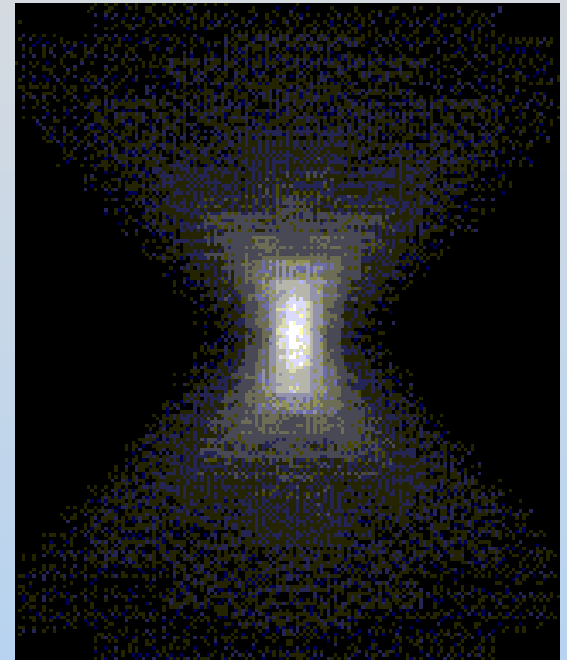

⇒ Image restoration by deconvolution

3.3 Deconvolution: survey

- Jansson - Van Cittert: pure least square solution
- Tikhonov-Miller: Regularization
- Richardson-Lucy: based on more statistical considerations

3.3.1 Jansson - Van Cittert

Direct least-square fitting: minimization of

$$\|g - h * f\|^2$$

Solving of the linear system with method of Gauss-Jacobi

- Pro: intuitive, easy, fast
- Contra: very sensitive to noise

3.3.2 Tikhonov-Miller

Least-square fitting with Tikhonov-regularization:
minimisation of

$$\Phi = \|g - h * f\|^2 - \lambda \|C * f\|^2$$

- “Quick Tikhonov-Miller”
 - ⇒ cfr Wiener filter
- Iterative solution: extra constraint that pixel values must be positive
 - ◆ Pro: better than Jansson-Van Cittert
 - ◆ Contra: still too much noise fitted

3.3.3 Richardson-Lucy (Maximum Likelihood Estimation)

Better criterium for quality of the solution
⇒ I-divergence

$$p(f | g) = \frac{p(g | f)p(f)}{p(g)}$$





$$L(f) = -\ln p(g | f)$$

$$e = h * f$$

$$\ln L(f) = \sum [g_i \cdot \ln e_i - e_i - \ln g_i!]$$

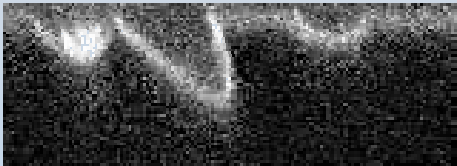
- Pro: best results
- Contra: computational intensive

3.3.4 Results

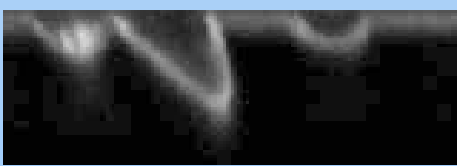
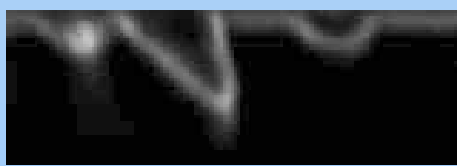
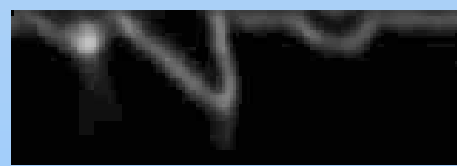
 <p>Onbewerkte opname</p>		
 <p>Wienerfilter</p>		
 <p>ICTM : 4 iteraties</p>	 <p>ICTM : 10 iteraties</p>	 <p>ICTM : 20 iteraties</p>
 <p>MLE : 4 iteraties</p>	 <p>MLE : 10 iteraties</p>	 <p>MLE : 20 iteraties</p>

4. Analysis procedures

4.1 ellipse fitting

Image analysis: fitting of an ellipse per optical slice

least square fitting to the quadratic equation

$$x^2 + a \cdot y^2 + b \cdot x \cdot y + c \cdot x + d \cdot y + e = 0$$

Then by reduction

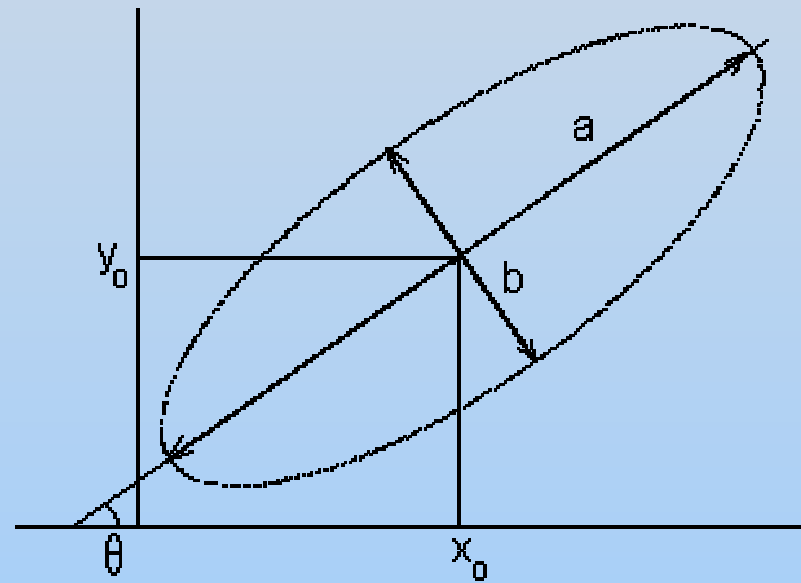

$$a, b, x_0, y_0, \theta$$

4.2 results

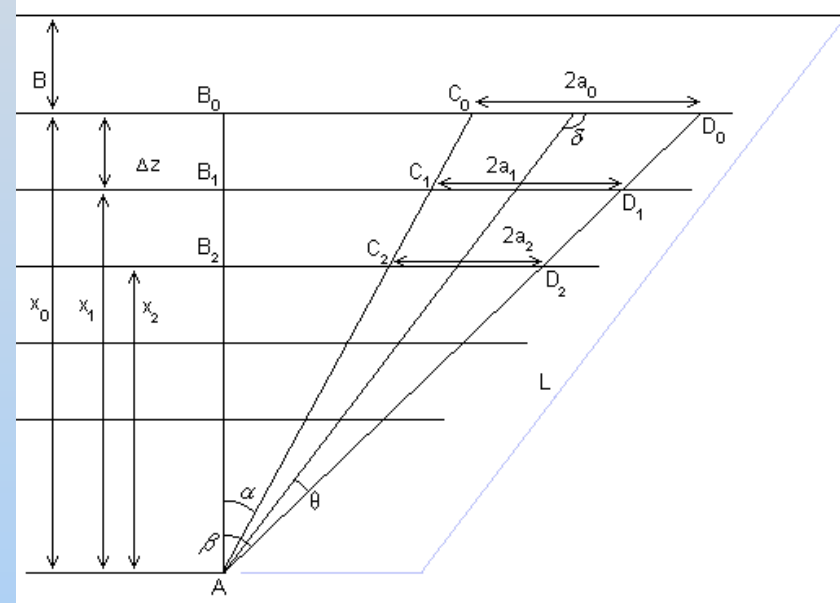
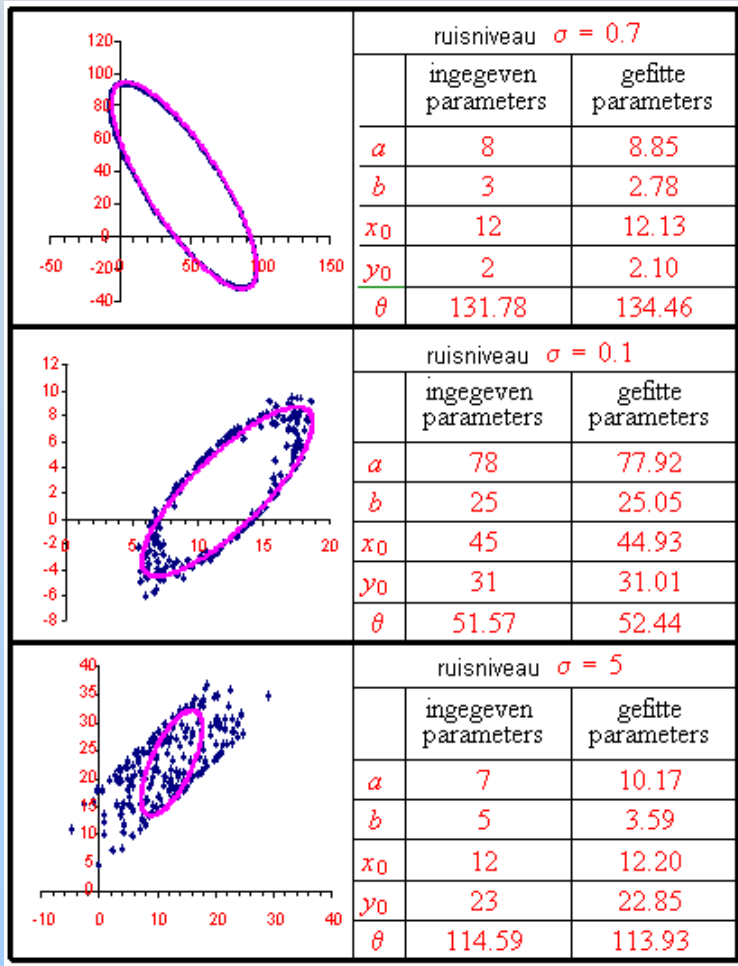

$$a_i = \left(1 - \frac{i \cdot \Delta z}{B \left(1 - \frac{\sin \delta}{\sin \theta} \right)} \right) \cdot a_0$$

4.3 first measurements

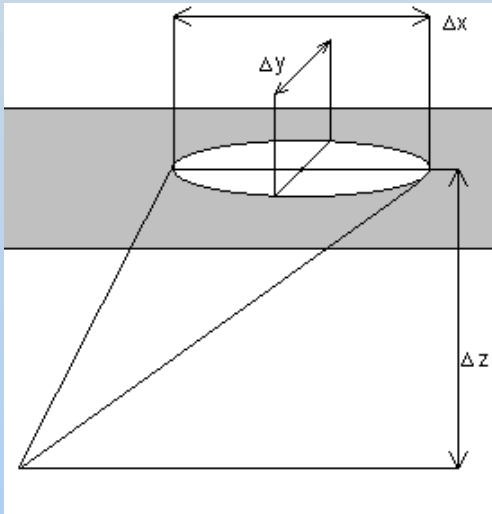

- Lithiumtracks

- $\Delta x = 5800 \text{ nm}$ ($\sigma(\Delta x) = 200 \text{ nm}$)
- $\Delta y = 6163,8 \text{ nm}$ ($\sigma(\Delta y) = 300 \text{ nm}$)
- $\Delta z = 9372,0 \text{ nm}$ ($\sigma(\Delta z) = 800 \text{ nm}$)

- alfa tracks

- $\Delta x = 18000 \text{ nm}$ ($\sigma(\Delta x) = 300 \text{ nm}$)
- $\Delta y = 18400 \text{ nm}$ ($\sigma(\Delta y) = 400 \text{ nm}$)
- $\Delta z = 15200 \text{ nm}$ ($\sigma(\Delta z) = 900 \text{ nm}$)

5. Conclusions

- Image restoration by deconvolution is OK, but still leaves space for improvements
 - more advanced methods with wavelets
 - PSF determination from smaller beads
 - more stable optical aligning
- ellipsfitting OK, begin cone fitting
 - should be completely automatical
- image segmentation (?)
 - non-ideal ellipses (dirt)
 - more ellipses in one image